



**LE FABLIER**

Valori *per sempre*



COLLEZIONE

LE GEMME



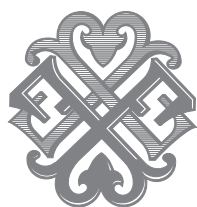

**LE FABLIER**

Valori *per* sempre

MADE IN ITALY





LA SEDUZIONE SOTTILE DI  
UN'ELEGANZA SENZA TEMPO.

*DISCREET SEDUCTION,*  
*TIMELESS ELEGANCE.*

L E G E M M E

L E G E M M E

G

I PREZIOSI DALLO SCRIGNO LE FABLIER

ELEGANTE, INTENSO, DECISAMENTE RAFFINATO, LO SPIRITO DEL GRANDE OTTOCENTO FRANCESE RIVIVE NELLA COLLEZIONE LE GEMME. LA SOLIDITÀ DEL TIGLIO TROVA FORMA NELLA MORBIDA LINEARITÀ E NELL'ACCURATISSIMO TRATTAMENTO DELLE SUPERFICI. UN'ARMONIA PREZIOSA, DALLA PIENA UNI-FORMITÀ TRA MATERIALI, PARTICOLARI COSTRUTTIVI E DECORATIVI. LA DIMENSIONE DEL CAPOLAVORO IN OGNI DETTAGLIO.

*WITH A SENSE OF ELEGANCE, INTENSITY AND DECISIVE REFINEMENT, THE SPIRIT OF THE GREAT FRENCH NINETEENTH CENTURY IS BROUGHT BACK WITH THE LE GEMME COLLECTION. THE STURDINESS OF LIME-TREE WOOD IS USED TO FORM SOFT LINES AND CAREFULLY WORKED SURFACES. A DELICATE HARMONY BETWEEN MATERIALS, CONSTRUCTION DETAILS AND DECORATIONS. A MASTERWORK IN EVERY DETAIL.*



135 Tormalina - Credenza tre ante  
135 Tormalina - 3-door cupboard  
135 Tormalina - Aparador 3 puertas

200 x 52 x 95



133 **Diaspro** - Tavolo rettangolare allungabile  
 133 **Diaspro** - Extendible rectangular table  
 133 **Diaspro** - Mesa rectangular extensible

160/244 x 90 x 79

134 **Ossidiana** - Sedia con schienale traforato  
 134 **Ossidiana** - Chair with fretworked back  
 134 **Ossidiana** - Silla con espalda calada

47 x 52 x 94

COLLEZIONE " LE GEMME GIORNO "



133 **Diaspro** - Particolare  
 133 **Diaspro** - Detail  
 133 **Diaspro** - Detalle

SOLO NEL TEMPO,  
 UN DESIDERIO DI SOLE  
 HA POTUTO TRASFORMARE IL BUIO DELLA TERRA  
 NELLA LUCE DELLE SUE GEMME.

*ONLY OVER TIME,  
 CAN THE DESIRE OF THE SUN  
 TRANSFORM THE DARKNESS OF THE EARTH  
 IN THE RADIANCE OF JEWELS.*





**122 Giada** - Credenza due ante con cassetti centrali  
**122 Giada** - 2-door cupboard with central drawers  
**122 Giada** - Aparador 2 puertas y cajones centrales

207 x 52 x 95

**132 Corniola** - Tavolo quadrato allungabile  
**132 Corniola** - Extendible square table  
**132 Corniola** - Mesa cuadrada extensible

110/170 x 110 x 79

**134 Ossidiana** - Sedia con schienale traforato  
**134 Ossidiana** - Chair with fretworked back  
**134 Ossidiana** - Silla con espalda calada

47 x 52 x 94





**I43 Brillante** - Argentiera due ante  
**I43 Brillante** - 2-door silverware  
**I43 Brillante** - Vitrina 2 puertas

157 x 48 x 200





143 Brillante - Argentiera due ante  
143 Brillante - 2-door silverware  
143 Brillante - Vitrina 2 puertas

157 x 48 x 200



132 Corniola - Tavolo quadrato allungabile  
 132 Corniola - Extendible square table  
 132 Corniola - Mesa cuadrada extensible

110/170 x 110 x 79

134 Ossidiana - Sedia  
 134 Ossidiana - Chair  
 134 Ossidiana - Silla

47 x 52 x 94

COLLEZIONE " LE GEMME GIORNO "



154 Azzurrite - Sedia  
 154 Azzurrite - Chair  
 154 Azzurrite - Silla

47 x 52 x 94



134 Ossidiana - Sedia  
 134 Ossidiana - Chair  
 134 Ossidiana - Silla

47 x 52 x 94







122 Giada - Credenza due ante con cassetti centrali

122 Giada - 2-door cupboard with central drawers

122 Giada - Aparador 2 puertas y cajones centrales







131 Lapislazzulo - Argentiera tre ante  
131 Lapislazzulo - 3-door silverware  
131 Lapislazzulo - Vitrina 3 puertas

191 x 48 x 200

COLLEZIONE " LE GEMME GIORNO "

COLORE, INCANTO DI LUCE.  
LE OMBRE SVANISCONO,  
CANCELLATE NELLA DANZA  
DI MILLE RIFLESSI SFUGGENTI,  
CATTURATI PER GIOIELLI DI DAMA.

*COLOUR: AN ENCHANTMENT OF LIGHT.  
WHERE SHADOWS DISAPPEAR  
UNDER THE DANCE  
OF A MILLION FLEETING REFLECTIONS,  
CAPTURED AS JEWELS OF A GRAND LADY.*





142 Cristallo di Rocca - argenteria un'anta  
142 Cristallo di Rocca - 1-door silverware  
142 Cristallo di Rocca - Vitrina 1 puerta

81 x 48 x 200





155 Agata - Credenza tre ante (laterali in vetro)  
 155 Agata - 3-door cupboard (side glass doors)  
 155 Agata - Aparador 1 puerta madera, (puertas laterales de cristal)

200 x 52 x 95

COLLEZIONE " LE GEMME GIORNO "



155 Agata - Particolare  
 155 Agata - Detail  
 155 Agata - Detalle

LA VERA BELLEZZA È COME UN SEGRETO.  
 DA CONDIVIDERE  
 SOLO CON CHI SI AMA,  
 SI OFFRE SOLO A CHI SA SCEGLIERE.

*TRUE BEAUTY IS LIKE A SECRET.  
 TO BE SHARED ONLY  
 WITH THOSE YOU LOVE  
 AND TO BE OFFERED ONLY TO THOSE  
 WHO KNOW HOW TO CHOOSE.*



126 Ematite - Credenza due ante  
126 Ematite - 2-door cupboard  
126 Ematite - Aparadors 2 puertas

160 x 52 x 95



126 Ematite - Particolare  
 126 Ematite - Detail  
 126 Ematite - Detalle

COLLEZIONE " LE GEMME GIORNO "



140 Opale - Tavolino  
 140 Opale - Small table  
 140 Opale - Mesita de noche

39 x 30 x 75

MAGIA DELLA PRIMAVERA.  
 ACCORGERSI CHE DAL GELO  
 NEL GRIGIO  
 SBOCCIANO I COLORI PIÙ BELLI.

*THE MAGIC OF SPRINGTIME.  
 TO REALIZE THAT FROM THE COLD  
 AND WINTRY GREY  
 THE MOST BEAUTIFUL COLOURS UNFOLD.*





129 Perla - Tavolo ovale allungabile  
129 Perla - Extendible oval table  
129 Perla - Mesa ovalada extensible

110 x 85/200 x 79



138 Amazonite - Consolle rettangolare  
 138 Amazonite - Rectangular console table  
 138 Amazonite - Cónsola rectangular

120 x 43 x 78

COLLEZIONE " LE GEMME GIORNO "



160 Aurea - Scrivania  
 160 Aurea - Writing desk  
 160 Aurea - Escritorio

140 x 70 x 80

NELL'ARMONIA

DI CIÒ CHE È COMPIUTO CON AMORE

VIVE UNA RARA COMPLETEZZA.

NULLA SI AGGIUNGE, NULLA SI TOGLIE.

TUTTO SI AMMIRA.

*THERE IS A RARE SENSE OF COMPLETION*

*IN THE HARMONY OF THOSE THINGS*

*THAT ARE DONE WITH LOVE.*

*THERE IS NOTHING TO ADD,*

*NOTHING TO TAKE AWAY.*

*EVERYTHING IS TO BE ADMIRER.*





141 Navette - Credenzina porta TV  
141 Navette - Small TV-cupboard  
141 Navette - Cónsola para TV

134 x 45 x 67



136 Malachite - Tavolino da salotto  
 136 Malachite - Small living room table  
 136 Malachite - Mesa de centro rectangular

125 x 80 x 45

COLLEZIONE " LE GEMME GIORNO "



137 Selenite - Tavolino quadrato da salotto  
 137 Selenite - Small square living room table  
 137 Selenite - Mesa de centro cuadrada

90 x 90 x 45

NON ESISTE FRETTA  
 CHE POSSA COMPIERE UN'OPERA PERFETTA.  
 PASSIONE, PAZIENZA, FIDUCIA.  
 COSÌ INSEGNA LA NATURA,  
 COSÌ NASCONO LE COSE MIGLIORI.

A PERFECT WORK  
 KNOWS NOTHING ABOUT HURRYING.  
 ONLY PASSION, PATIENCE AND TRUST.  
 THIS IS WHAT NATURE TEACHES US,  
 AND THIS IS HOW THE BEST THINGS ARE CREATED.









LASCIARE SPAZIO ALL'INVISIBILE.  
QUANDO LA BELLEZZA  
SI FA SPECCHIO DI UN'ESSENZA PROFONDA,  
LA FORMA VOLGE IN POESIA.

*LEAVE SPACE FOR UNSEEN THINGS.  
WHEN BEAUTY  
MIRRORS A PROFOUND ESSENCE,  
ITS SHAPE TAKES FORM AS POETRY.*

COLLEZIONE " LE GEMME GIORNO "

**146 Acquamarina** - Libreria/consolle retrodivano  
**146 Acquamarina** - Bookcase/consolle table for behind sofa  
**146 Acquamarina** - Cónsola detrás sofá

140 x 39 x 78





157 Corallo - Letto traforato a giroletto  
157 Corallo - Fretworked bed without footboard  
157 Corallo - Cama calada sin piecero

168 x 218 x 109

115 Topazio - Comò  
115 Topazio - Chest of drawers  
115 Topazio - Cómoda

122 x 54 x 105

112 Zaffiro - Comodino  
112 Zaffiro - Bedside table  
112 Zaffiro - Mesita de noche

54 x 35 x 66



GLAM - Lampada  
GLAM - Lamp  
GLAM - Lampara

25 x 13 x 40

GLAM - Lampada da terra  
GLAM - Floor lamp  
GLAM - Lampara de pie

43 x 23 x 165





116 Corallo - Letto traforato  
116 Corallo - Fretworked bed  
116 Corallo - Cama calada

168 x 220 x 109

117 Zircone - Comodino a giorno  
117 Zircone - Open bedside table  
117 Zircone - Mesita de noche abierta

52 x 36 x 68

MISS - Lampada  
MISS - Lamp  
MISS - Lampara

Ø 22 x h.42

HARI - Lampada da terra  
HARI - Floor lamp  
HARI - Lampara de pie

Ø 50 x h.180





113 Ambra - Specchiera  
113 Ambra - Mirror  
113 Ambra - Espejo

72 x 3 x 92

115 Topazio - Comò  
115 Topazio - Chest of drawers  
115 Topazio - Cómoda

122 x 54 x 105

HARI - Lampada  
HARI - Lamp  
HARI - Lampara

Ø 35 x h.59









COLLEZIONE "GEMME NOTTE"



109 Diamante - Comò apribile  
 109 Diamante - Openable chest of drawers  
 109 Diamante - Cómoda abrible

141 x 54 x 91

MISS - Lampada  
 MISS - Lamp  
 MISS - Lampara

Ø 28 x h.55





III Smeraldo - Comò con ribalta  
III Smeraldo - Chest of drawers with flap  
III Smeraldo - Cómoda con hoja

406 Aneto - Specchio  
406 Aneto - Mirror  
406 Aneto - Espejo

126 x 54 x 122

87 x 6 x 107





163 Pavè - Specchio laccato nero  
163 Pavè - Black laquered mirror  
163 Pavè - Espejo lacado negro

121 x 3 x 121



112 Zaffiro - Comodino  
112 Zaffiro - Bedside table  
112 Zaffiro - Mesita da noche

54 x 35 x 66

MISS - Lampada  
MISS - Lamp  
MISS - Lampara

Ø 22 x h.42



169 **Eliodoro** - Letto con contenitore  
169 **Eliodoro** - Lift up storage bed  
169 **Eliodoro** - Cama con almacenamiento

189 x 210 x 114

540 **Gem** - Tavolino rotondo con rotelle  
540 **Gem** - Round small table with castors  
540 **Gem** - Mesita redonda con ruedas

Ø 52 x h.63

MISS - Lampada  
MISS - Lamp  
MISS - Lampara

Ø 22 x h.42

GLAM - Lampada  
GLAM - Lamp  
GLAM - Lampara

25 x 13 x 40



COLLEZIONE "GEMME NOTTE"

160 Aurea - Scrivania  
 160 Aurea - Desk  
 160 Aurea - Escritorio

140 x 70 x 80

571 Venus - Poltrona per ufficio  
 571 Venus - Office chair  
 571 Venus - Silla de oficina

57 x 60 x 95





**156 Granato** - Letto con pelle  
**156 Granato** - Bed with leather headboard  
**156 Granato** - Cama con cabecera en piel

168 x 220 x 109

**117 Zircone** - Comodino a giorno  
**117 Zircone** - Open bedside table  
**117 Zircone** - Mesita de noche abierta

52 x 36 x 68

**MISS** - Lampada  
**MISS** - Lamp  
**MISS** - Lampara

Ø 22 x h.42





150 Ametista - Cassettiera  
150 Ametista - Dresser  
150 Ametista - Cajonera

50 x 36 x 129

COLLEZIONE "GEMME NOTTE"





109 Diamante - Comò apribile  
109 Diamante - Openable chest of drawers  
109 Diamante - Cómoda abrible

HARI - Lampada  
HARI - Lamp  
HARI - Lampara

141 x 54 x 91

Ø 35 x h.59



COLLEZIONE "GEMME NOTTE"





**166 Silicio** - Letto con testata imbottita  
**166 Silicio** - Bed with padded headboard  
**166 Silicio** - Cama con cabecera acolchada

172 x 222 x 111

**117 Zircone** - Comodino a giorno  
**117 Zircone** - Open bedside table  
**117 Zircone** - Mesita de noche abierta

52 x 36 x 68



COLLEZIONE "GEMME NOTTE"

- 117 Zircone - Comodino a giorno
- 117 Zircone - Open bedside table
- 117 Zircone - Mesita de noche abierta

52 x 36 x 68





166 Silicio - Letto con testata imbottita  
166 Silicio - Bed with padded headboard  
166 Silicio - Cama con cabecera acolchada

172 x 222 x 111





177 Iridio - Armadio 2 ante scorrevoli  
177 Iridio - 2 sliding doors wardrobe  
177 Iridio - Armario 2 puertas correderas

293 x 70 x 258





COLLEZIONE "GEMME NOTTE"

PERDUTO  
È TUTTO IL TEMPO  
CHE IN AMOR  
NON SI SPENDE.

*ALL THE TIME  
IS LOST,  
THAT LOVE  
DOES NOT SPEND.*

**178 Iridio** - Armadio 2 ante scorrevoli con specchi  
**178 Iridio** - 2 sliding doors wardrobe with mirrors  
**178 Iridio** - Armario 2 puertas correderas con espejos

293 x 70 x 258





114 Rubino - Armadio 4 ante  
114 Rubino - 4-door wardrobe  
114 Rubino - Armario 4 puertas

285 x 64 x 247





119 *Quarzo* - Armadio 5 ante  
119 *Quarzo* - 5-door wardrobe  
119 *Quarzo* - Armario 5 puertas

304 x 64 x 247





101 - Composizione armadio 3 ante  
101 - 3-door wardrobe composition  
101 - Composicion armario 3 puertas

195 x 65 x 253





102 - Composizione armadio 4 ante  
102 - 4-door wardrobe composition  
102 - Composicion armario 4 puertas

255 x 65 x 253







103 - Composizione ad angolo 6 ante  
103 - 6-door angular composition  
103 - Composicion angular 6 puertas

295+233 x 65 x 253





104 - Composizione ad angolo 5 ante + cassetti + vano TV  
104 - 5-door angular composition + drawers + TV compartment  
104 - Composicion angular 5 puertas + cajones + compartimiento de TV

256+195 x 65 x 253





105 - Composizione armadio 6 ante + cassetti  
105 - 6-door wardrobe composition + drawers  
105 - Composicion armario 6 puerta + cajones

376 x 65 x 253





106 - Composizione armadio 6 ante + cassetti + vano TV  
106 - 6-door wardrobe composition + drawers + TV compartment  
106 - Composicion armario 6 puertas + cajones + compartimiento de TV

376 x 65 x 253







107 - Composizione armadio 6 ante  
107 - 6-door wardrobe composition  
107 - Composicion armario 6 puertas

376 x 65 x 253





Tutte le misure presenti nel catalogo sono espresse in centimetri,  
nella sequenza: Larghezza - Profondità - Altezza.

*All measurements mentioned in the catalogue are expressed  
in centimeters as Width - Depth - Height.*

*Todas las medidas en el catalogo son en centimetros  
en el siguiente orden: Ancho - Profundidad - Altura*

A B A C O  
A B A C U S  
A B A C O

A

LE GEMME GIORNO - NOTTE

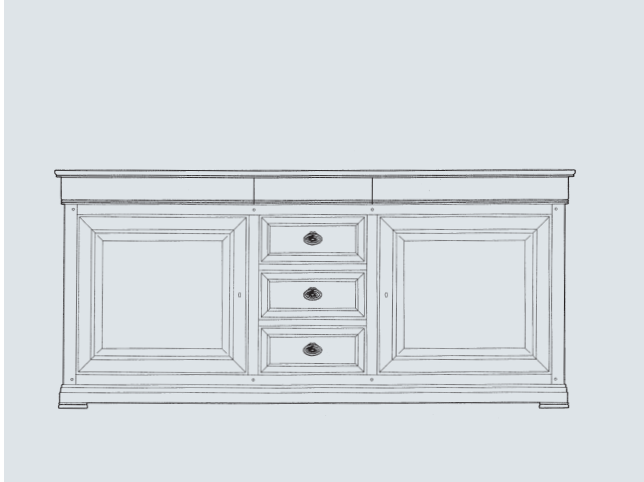

**122 Giada** - Credenza 2 ante con cassetti  
**122 Giada** - 2-door cupboard  
**122 Giada** - Aparador 2 puertas y cajones

207 × 52 × 95

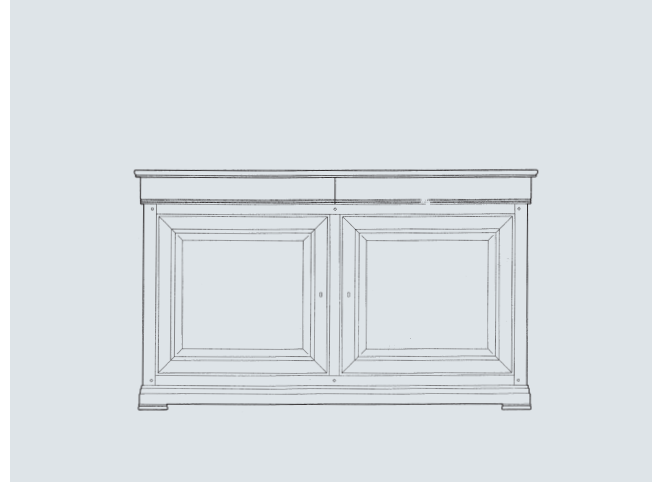

**126 Ematite** - Credenza 2 ante  
**126 Ematite** - 2-door cupboard  
**126 Ematite** - Aparadors 2 puertas

160 × 52 × 95

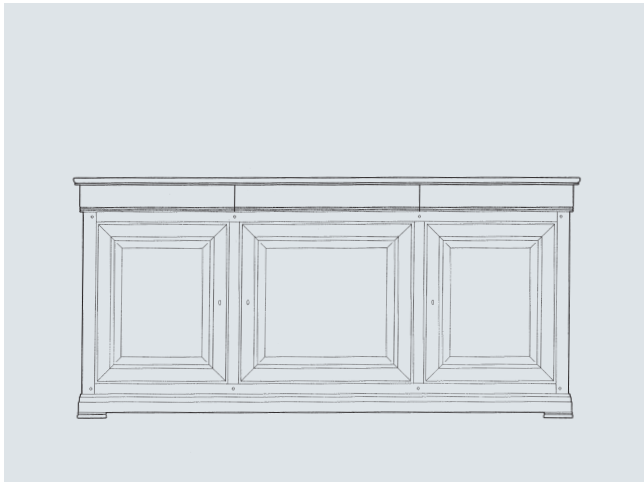

**135 Tormalina** - Credenza 3 ante  
**135 Tormalina** - 3-door cupboard  
**135 Tormalina** - Aparador 3 puertas

200 × 52 × 95

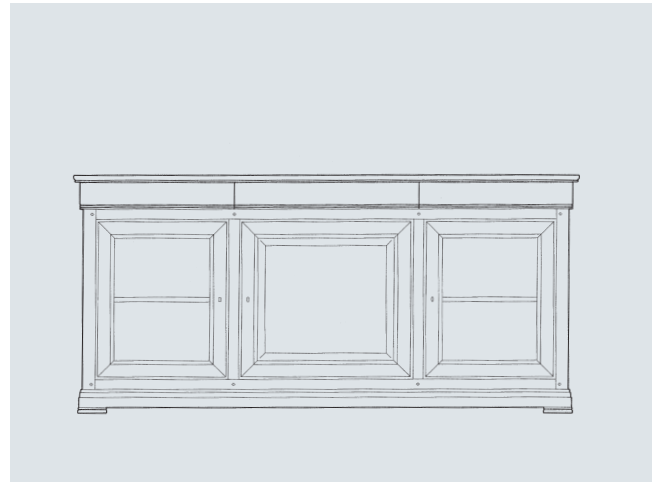

**155 Agata** - Credenza 3 ante (lateralì in vetro)  
**155 Agata** - 3-door cupboard (side glass doors)  
**155 Agata** - Aparador 1 puerta madera, 2 puertas cristal

200 × 52 × 95

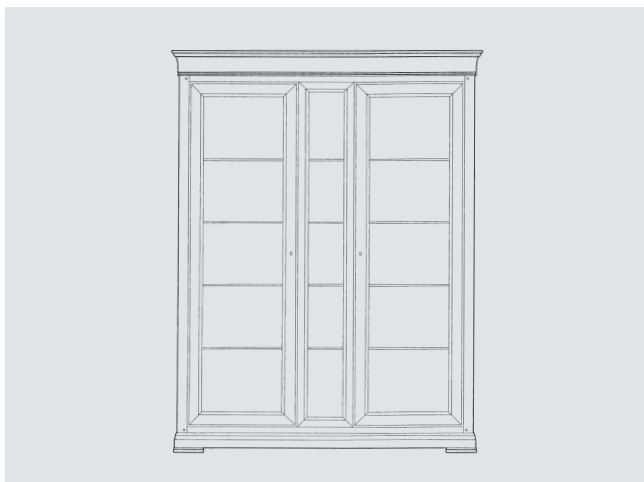

**143 Brillante** - Argentiera 2 ante  
**143 Brillante** - 2-door silverware  
**143 Brillante** - Vitrina 2 puertas

157 × 48 × 200



**131 Lapislazzulo** - Argentiera 3 ante  
**131 Lapislazzulo** - 3-door silverware  
**131 Lapislazzulo** - Vitrina 3 puertas

191 × 48 × 200

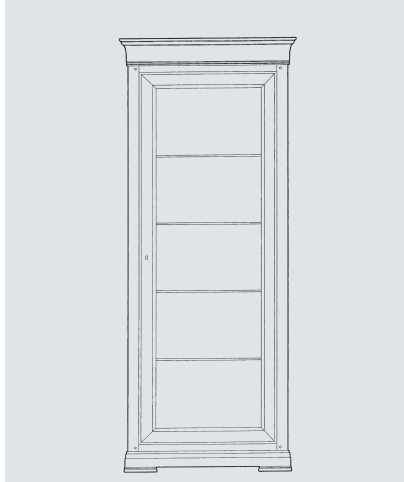

**142 Cristallo di Rocca** - Argenteria 1 anta  
*142 Cristallo di Rocca - Silverware*  
*142 Cristallo di Rocca - Vitrina 1 puerta*

81 × 48 × 200

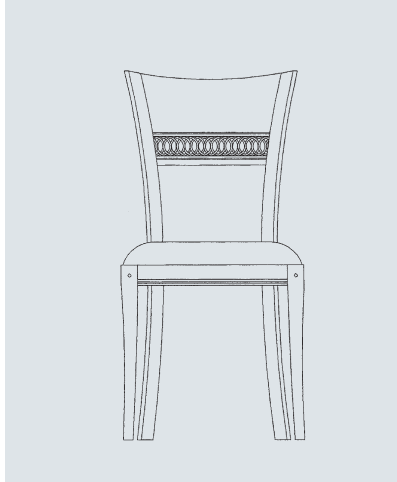

**134 Ossidiana** - Sedia con schienale traforato  
*134 Ossidiana - Chair with fretworked back*  
*134 Ossidiana - Silla con espalda calada*

47 × 52 × 94

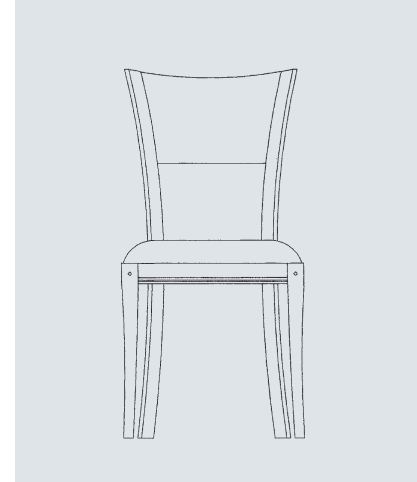

**154 Azzurrite** - Sedia  
*154 Azzurrite - Chair*  
*154 Azzurrite - Silla*

47 × 52 × 94

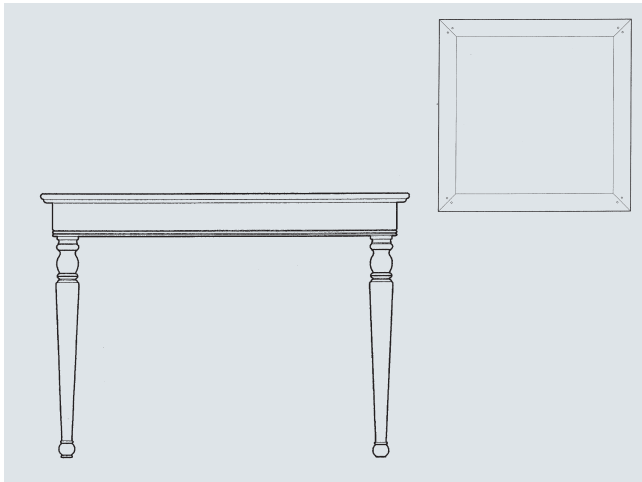

**132 Corniola** - Tavolo quadrato allungabile  
*132 Corniola - Square extendible table*  
*132 Corniola - Mesa cuadrada extensible*

110/170 × 110 × 79

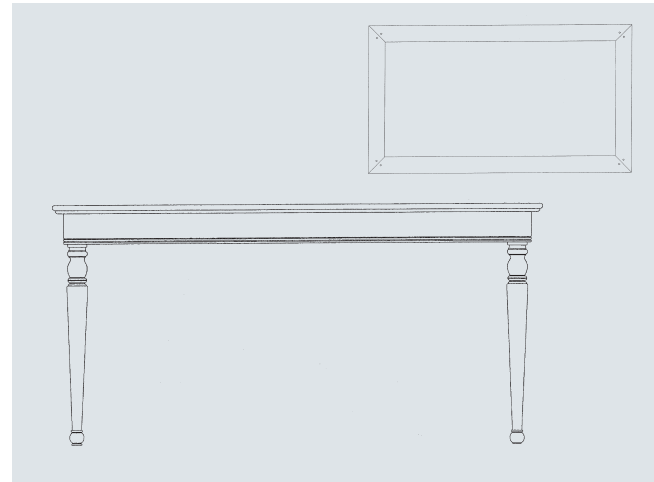

**133 Diaspro** - Tavolo rettangolare allungabile  
*133 Diaspro - Rectangular extendible table*  
*133 Diaspro - Mesa rectangular extensible*

160/244 × 90 × 79

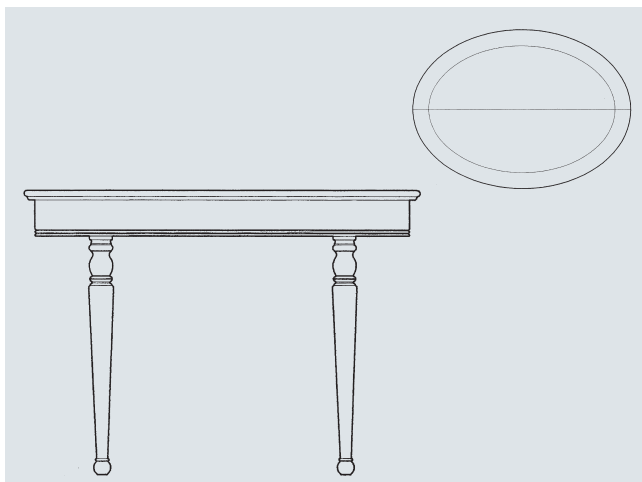

**129 Perla** - Tavolo ovale allungabile  
*129 Perla - Oval extendible table*  
*129 Perla - Mesa ovalada extensible*

110 × 85/200 × 79

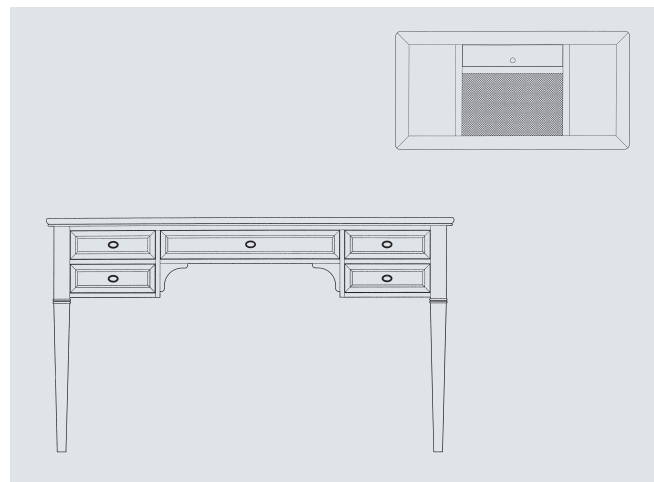

**160 Aurea** - Scrivania  
*160 Aurea - Writing desk*  
*160 Aurea - Escritorio*

140 × 70 × 80



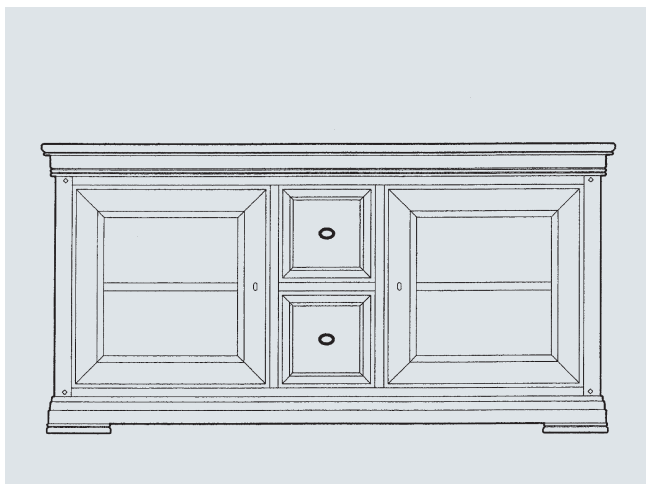

**141 Navette** - Credenzina porta TV  
**141 Navette** - TV table  
**141 Navette** - Cónsola para TV

134 x 45 x 67

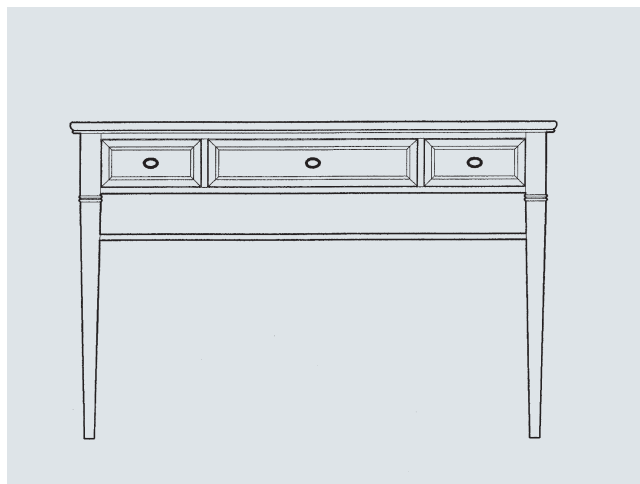

**138 Amazonite** - Console rettangolare  
**138 Amazonite** - Rectangular console  
**138 Amazonite** - Cónsola rectangular

120 x 43 x 78

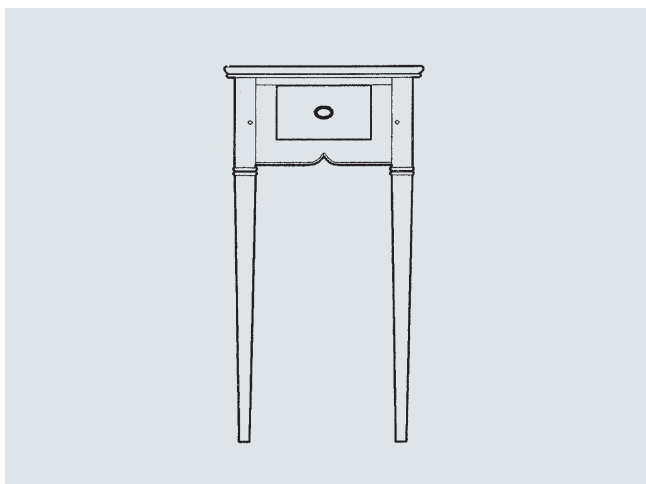

**140 Opale** - Comodino alto a giorno  
**140 Opale** - Bedside table  
**140 Opale** - Mesita de noche

39 x 30 x 75

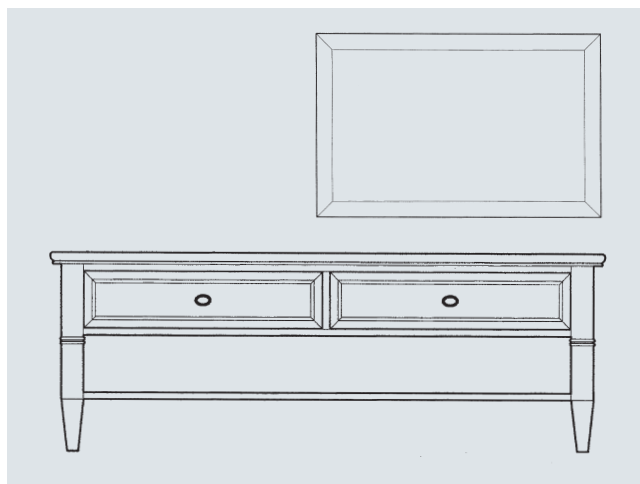

**136 Malachite** - Tavolino da salotto rettangolare  
**136 Malachite** - Rectangular coffee table  
**136 Malachite** - Mesa de centro rectangular

125 x 80 x 45

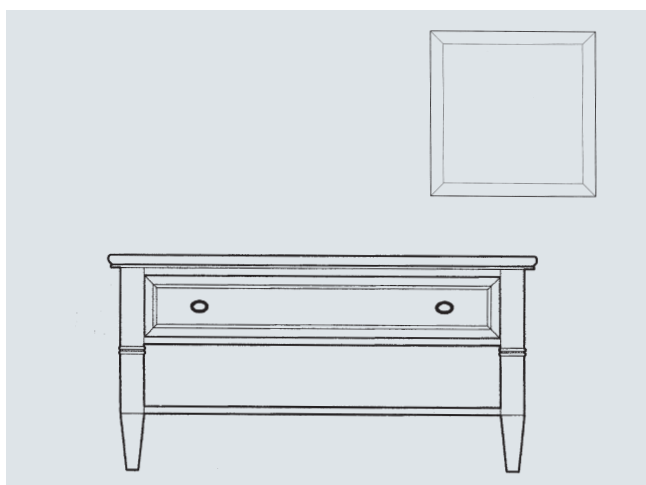

**137 Selenite** - Tavolino da salotto quadrato  
**137 Selenite** - Square coffee table  
**137 Selenite** - Mesa de centro cuadrada

90 x 90 x 45

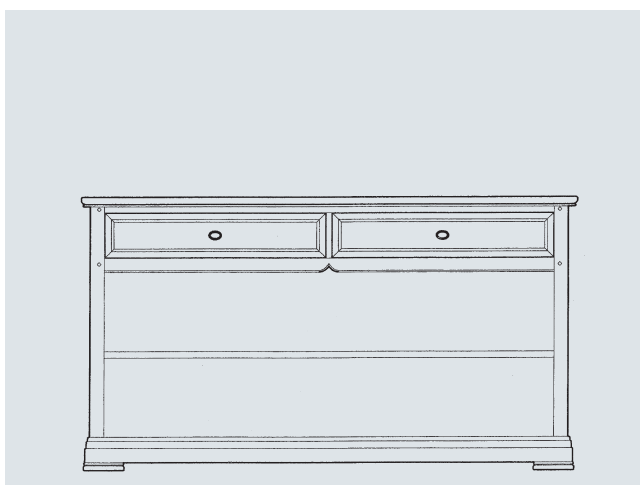

**146 Acquamarina** - Libreria/Retrodivano  
**146 Acquamarina** - Bookcase/Console  
**146 Acquamarina** - Cónsola detrás sofá

140 x 39 x 78





**109 Diamante** - Comò apribile  
**109 Diamante** - Openable chest of drawers  
**109 Diamante** - Cómida abrible

141 x 54 x 91



**111 Smeraldo** - Comò con ribalta  
**111 Smeraldo** - Chest of drawers with flap  
**111 Smeraldo** - Cómida con hoja

126 x 54 x 122



**115 Topazio** - Comò  
**115 Topazio** - Chest of drawers  
**115 Topazio** - Cómida

122 x 54 x 105



**115 Acc** - Accessorio per comò art.115  
**115 Acc** - Accessory for chest of drawer art.115  
**115 Acc** - Accesorio para cómoda art. 115





**112 Zaffiro** - Comodino con cassetti  
*112 Zaffiro* - Bedside table  
*112 Zaffiro* - Mesita de noche

54 x 35 x 66

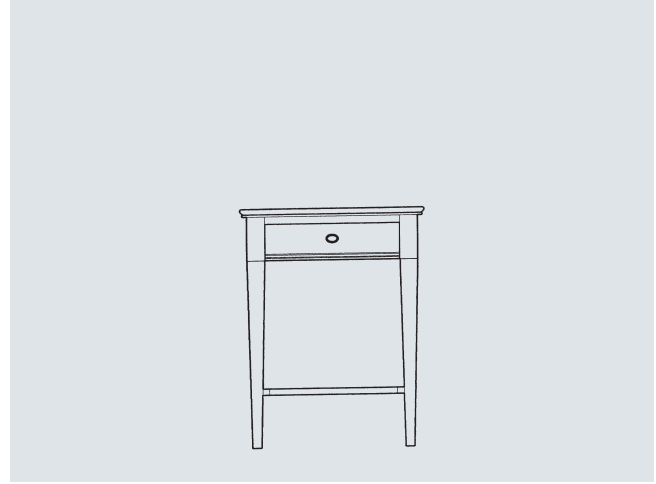

**117 Zircone** - Comodino a giorno  
*117 Zircone* - Open bedside table  
*117 Zircone* - Mesita de noche abierta

52 x 36 x 68



**150 Ametista** - Cassettiera  
*150 Ametista* - Dresser  
*150 Ametista* - Cajonera

50 x 36 x 129

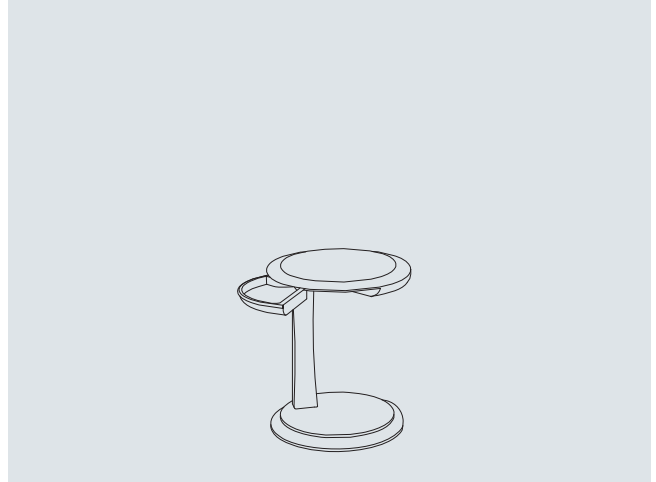

**540 Gem** - Tavolino rotondo con rotelle  
*540 Gem* - Round small table with castors  
*540 Gem* - Mesita redonda con ruedas

Ø 52 x 63

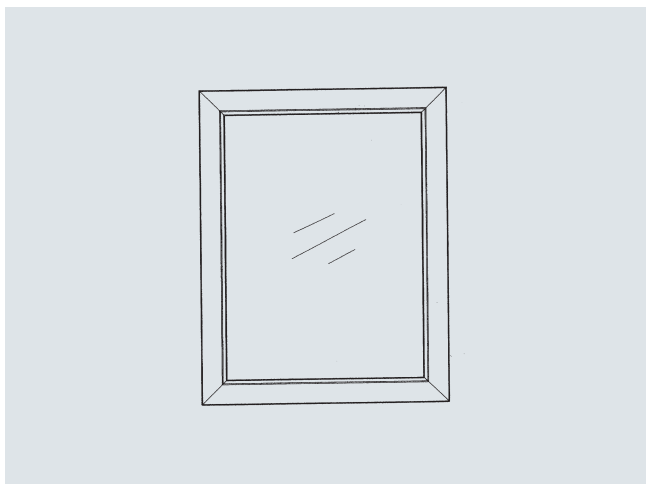

**113 Ambra** - Specchiera  
**113 Ambra** - Mirror  
**113 Ambra** - Espejo

72 x 3 x 92



**163 Pavè** - Specchio  
**163 Pavè** - Mirror  
**163 Pavè** - Espejo

121 x 3 x 121

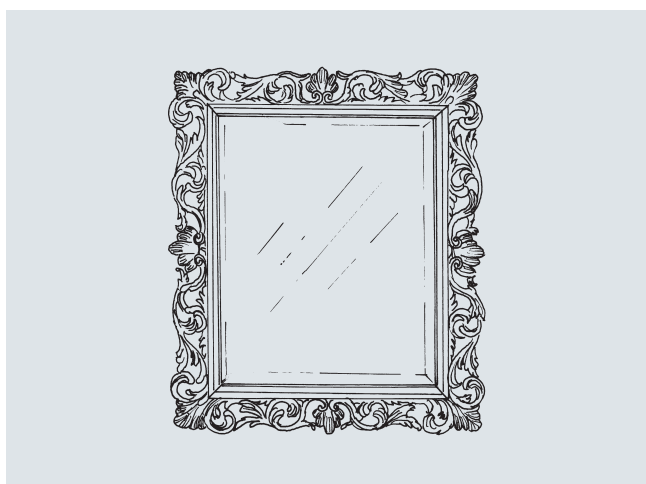

**406 Aneto** - Specchio  
**406 Aneto** - Mirror  
**406 Aneto** - Espejo

87 x 6 x 107



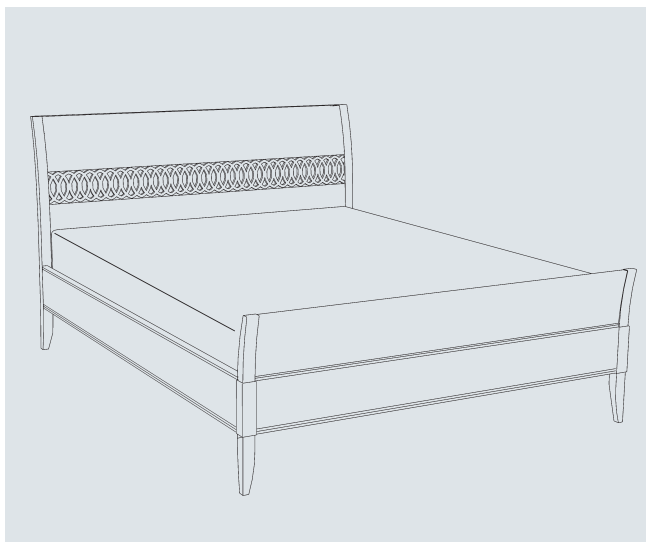

**116-90 Corallo** - Letto traforato  
*116-90 Corallo* - Fretworked bed  
*116-90 Corallo* - Cama calada

98 x 220 x 109

**116-120 Corallo** - Letto traforato  
*116-120 Corallo* - Fretworked bed  
*116-120 Corallo* - Cama calada

128 x 220 x 109

**116-140 Corallo** - Letto traforato  
*116-140 Corallo* - Fretworked bed  
*116-140 Corallo* - Cama calada

148 x 220 x 109

**116-160 Corallo** - Letto traforato  
*116-160 Corallo* - Fretworked bed  
*116-160 Corallo* - Cama calada

168 x 220 x 109

**116-180 Corallo** - Letto traforato  
*116-180 Corallo* - Fretworked bed  
*116-180 Corallo* - Cama calada

188 x 220 x 109

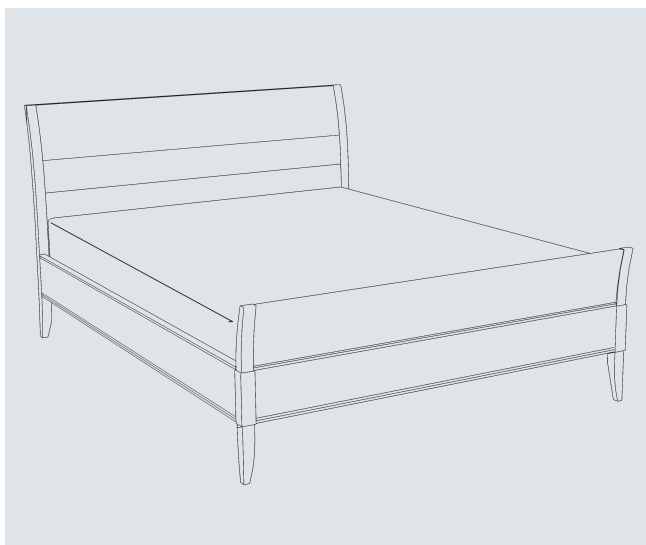

**156-90 Granato** - Letto con pelle  
*156-90 Granato* - Bed with leather headboard  
*156-90 Granato* - Cama con cabecera en piel

98 x 220 x 109

**156-120 Granato** - Letto con pelle  
*156-120 Granato* - Bed with leather headboard  
*156-120 Granato* - Cama con cabecera en piel

128 x 220 x 109

**156-140 Granato** - Letto con pelle  
*156-140 Granato* - Bed with leather headboard  
*156-140 Granato* - Cama con cabecera en piel

148 x 220 x 109

**156-160 Granato** - Letto con pelle  
*156-160 Granato* - Bed with leather headboard  
*156-600 Granato* - Cama con cabecera en piel

168 x 220 x 109

**156-180 Granato** - Letto con pelle  
*156-180 Granato* - Bed with leather headboard  
*156-180 Granato* - Cama con cabecera en piel

188 x 220 x 109

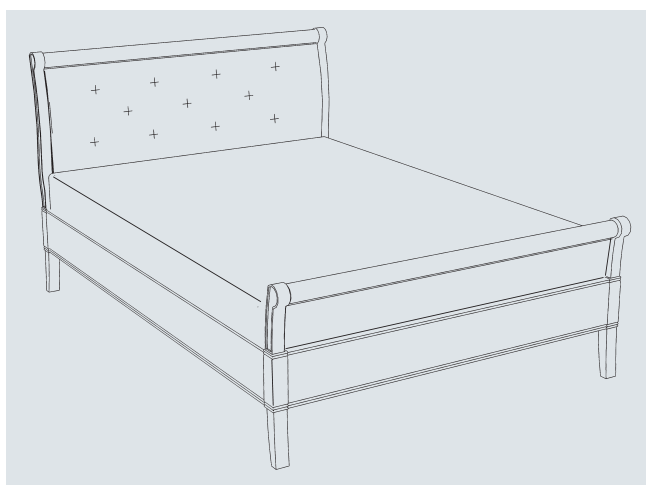

**166 Silicio** - Letto con testata imbottita  
*166 Silicio* - Bed with padded headboard  
*166 Silicio* - Cama con cabecera acolchada

172 x 222 x 111

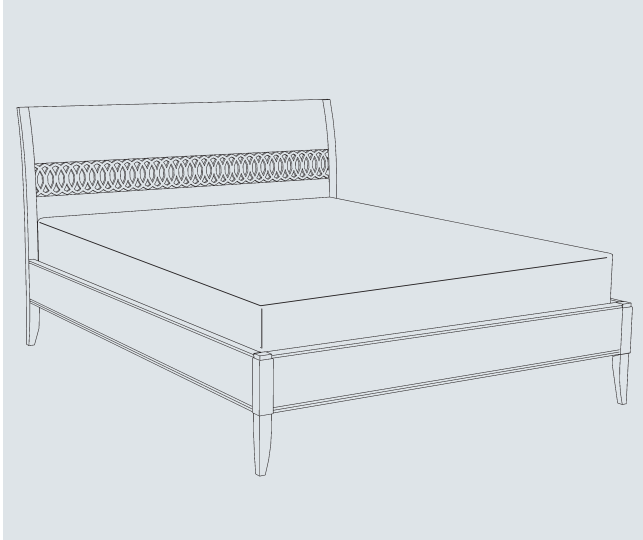

**157-90 Corallo** - Letto traforato a giroletto  
*157-90 Corallo - Fretworked bed without footboard*  
*157-90 Corallo - Cama calada sin piecero*

98 x 220 x 109

**157-120 Corallo** - Letto traforato a giroletto  
*157-120 Corallo - Fretworked bed without footboard*  
*157-120 Corallo - Cama calada sin piecero*

128 x 220 x 109

**157-140 Corallo** - Letto traforato a giroletto  
*157-140 Corallo - Fretworked bed without footboard*  
*157-140 Corallo - Cama calada sin piecero*

148 x 220 x 109

**157-160 Corallo** - Letto traforato a giroletto  
*157-160 Corallo - Fretworked bed without footboard*  
*157-160 Corallo - Cama calada sin piecero*

168 x 220 x 109

**157-180 Corallo** - Letto traforato a giroletto  
*157-180 Corallo - Fretworked bed without footboard*  
*157-180 Corallo - Cama calada sin piecero*

188 x 220 x 109

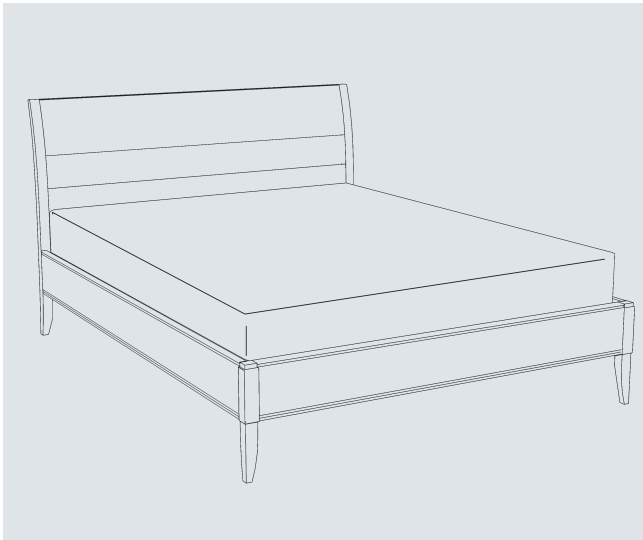

**158-90 Granato** - Letto con pelle a giroletto  
*158-90 Granato - Bed with leather headboard without footboard*  
*158-90 Granato - Cama con cabecera en piel y sin piecero*

98 x 220 x 109

**158-120 Granato** - Letto con pelle a giroletto  
*158-120 Granato - Bed with leather headboard without footboard*  
*158-120 Granato - Cama con cabecera en piel y sin piecero*

128 x 220 x 109

**158-140 Granato** - Letto con pelle a giroletto  
*158-140 Granato - Bed with leather headboard without footboard*  
*158-140 Granato - Cama con cabecera en piel y sin piecero*

148 x 220 x 109

**158-160 Granato** - Letto con pelle a giroletto  
*158-160 Granato - Bed with leather headboard without footboard*  
*158-160 Granato - Cama con cabecera en piel y sin piecero*

168 x 220 x 109

**158-180 Granato** - Letto con pelle a giroletto  
*158-180 Granato - Bed with leather headboard without footboard*  
*158-180 Granato - Cama con cabecera en piel y sin piecero*

188 x 220 x 109

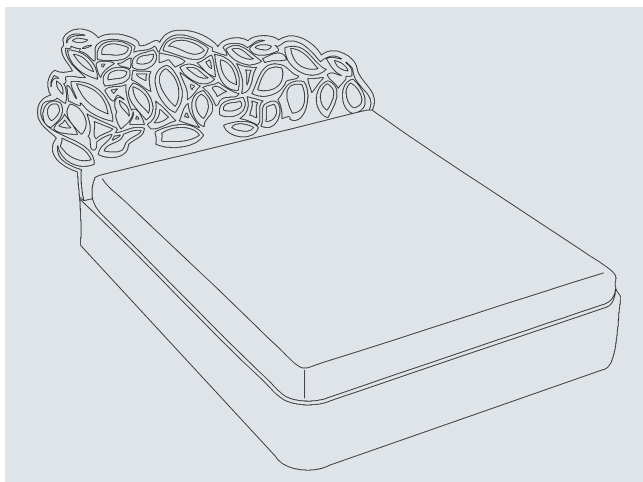

**169 Eliodoro** - Letto con contenitore  
*169 Eliodoro - Lift up storage bed*  
*169 Eliodoro - Cama con almacenamiento*

189 x 210 x 114



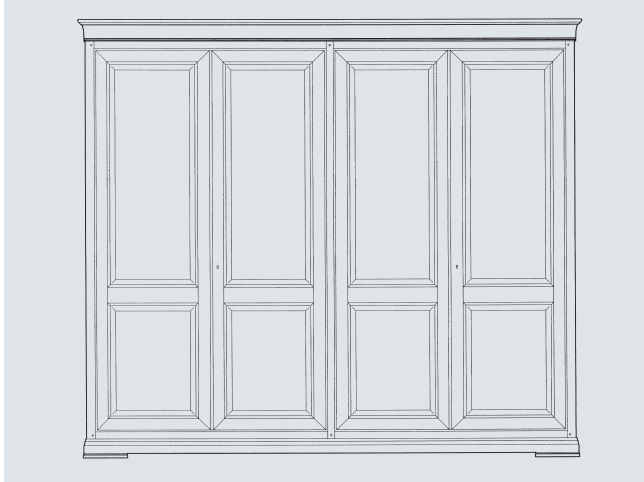

114 Rubino - Armadio 4 ante  
 114 Rubino - 4-door wardrobe  
 114 Rubino - Armario 4 puertas

285 x 64 x 247

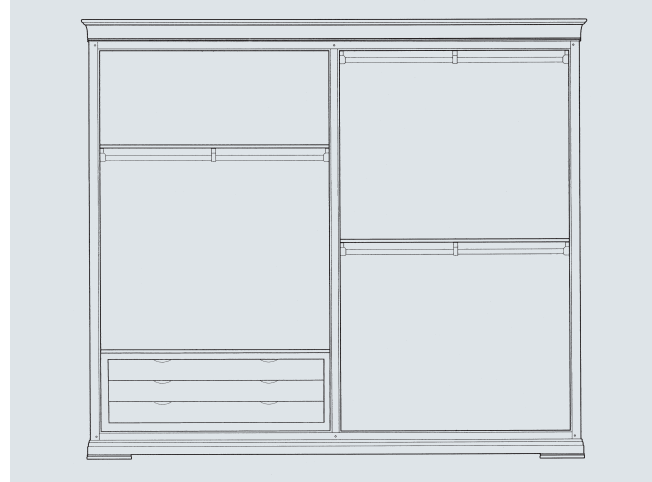

114 Rubino - Interno armadio  
 114 Rubino - Inner wardrobe  
 114 Rubino - Interno armario

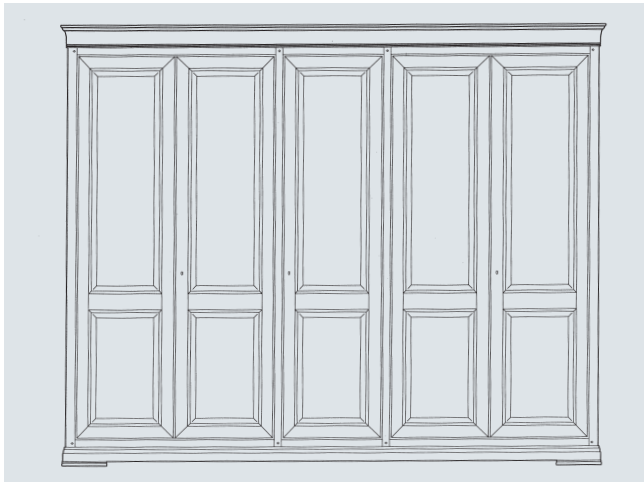

119 Quarzo - Armadio 5 ante  
 119 Quarzo - 5-door wardrobe  
 119 Quarzo - Armario 5 puertas

304 x 64 x 247

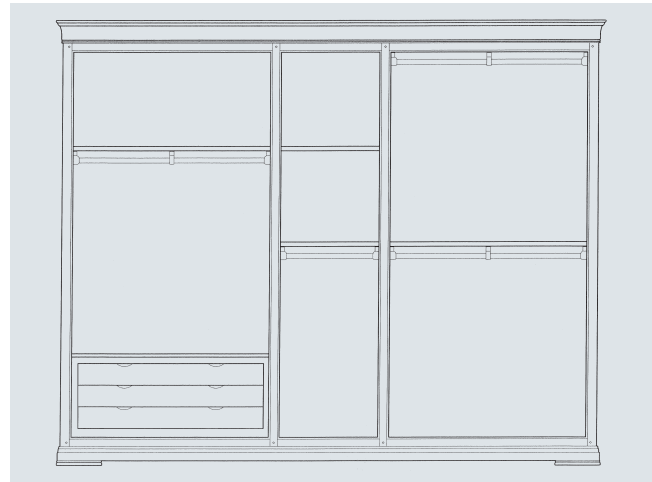

119 Quarzo - Interno armadio  
 119 Quarzo - Inner wardrobe  
 119 Quarzo - Interno armario

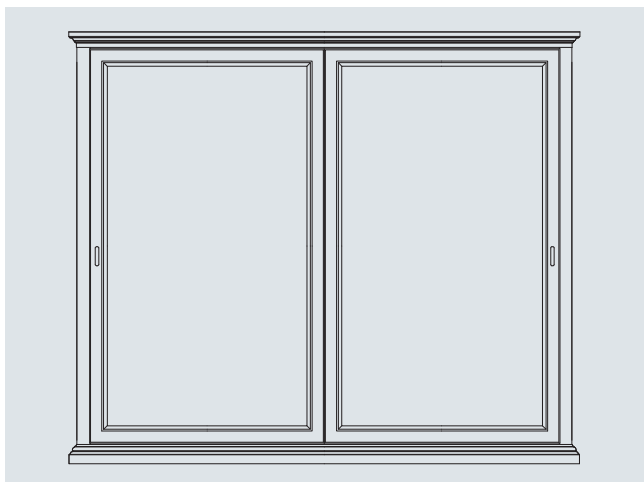

177 Iridio - Armadio 2 ante scorrevoli  
 177 Iridio - 2 sliding doors wardrobe  
 177 Iridio - Armario 2 puertas correderas

293 x 70 x 258

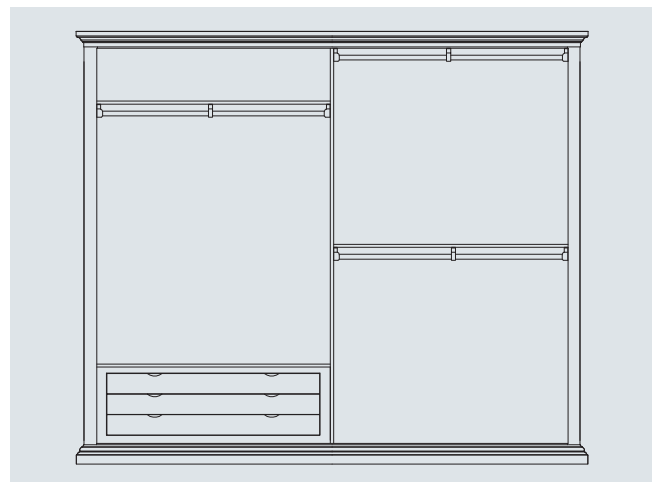

177 Iridio - Interno armadio  
 177 Iridio - Inner wardrobe  
 177 Iridio - Interno armario

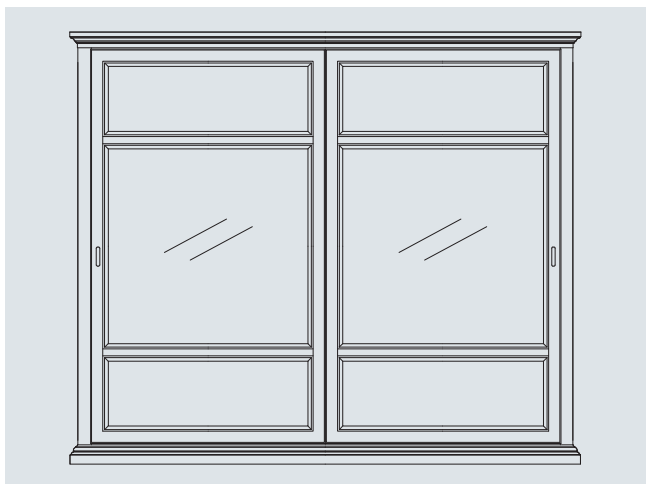

**178 Iridio** - Armadio 2 ante scorrevoli con specchio bronzo  
**178 Iridio** - 2 sliding doors wardrobe  
**178 Iridio** - Armario 2 puertas correderas

293 x 70 x 258

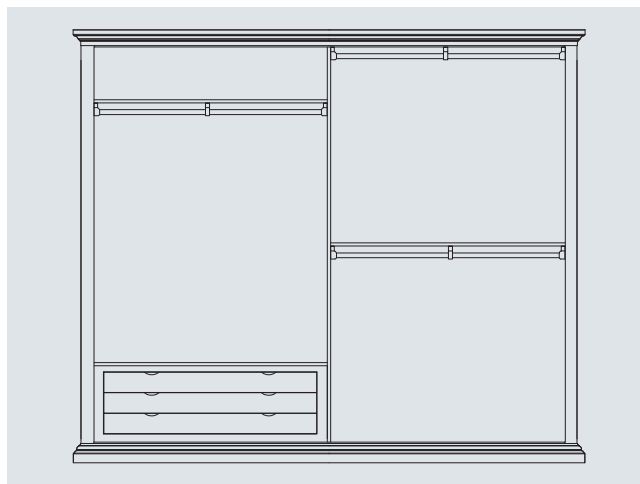

**178 Iridio** - Interno armadio  
**178 Iridio** - Inner wardrobe  
**178 Iridio** - Interno armario

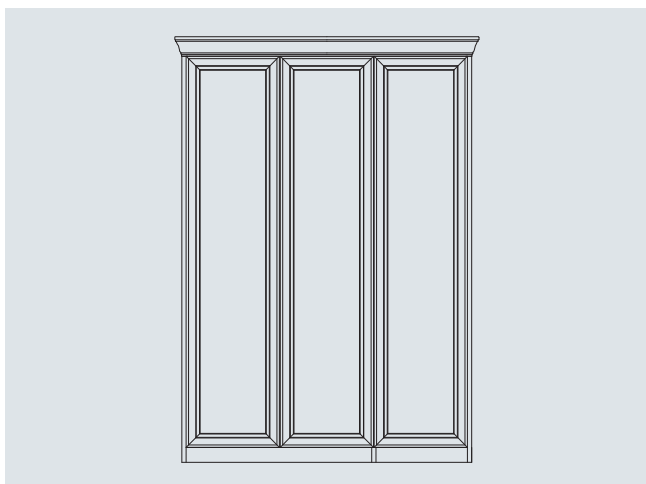

**101** - Composizione armadio 3 ante  
**101** - 3-door wardrobe composition  
**101** - Composicion armario 3 puertas

195 x 65 x 253

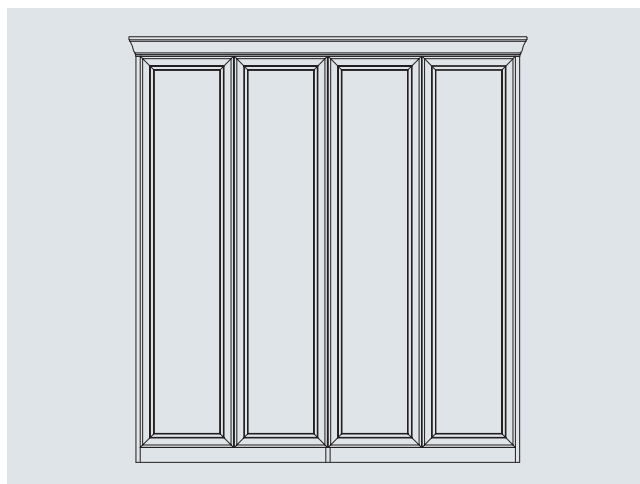

**102** - Composizione armadio 4 ante  
**102** - 4-door wardrobe composition  
**102** - Composicion armario 4 puertas

255 x 65 x 253

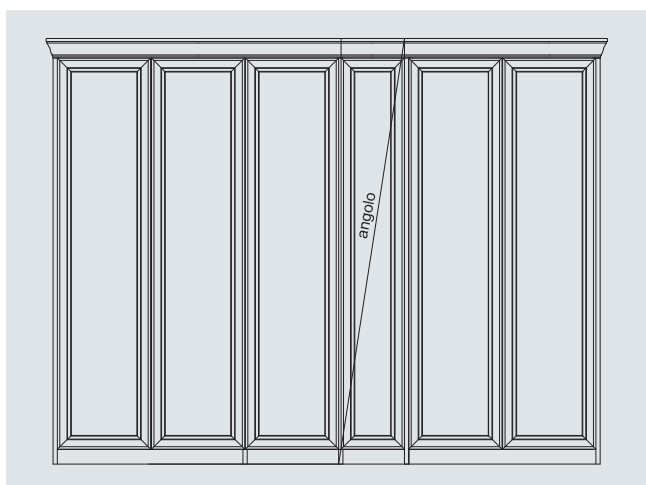

**103** - Composizione armadio ad angolo 6 ante  
**103** - 6-door angular composition  
**103** - Composicion angular 6 puertas

295+233 x 65 x 253

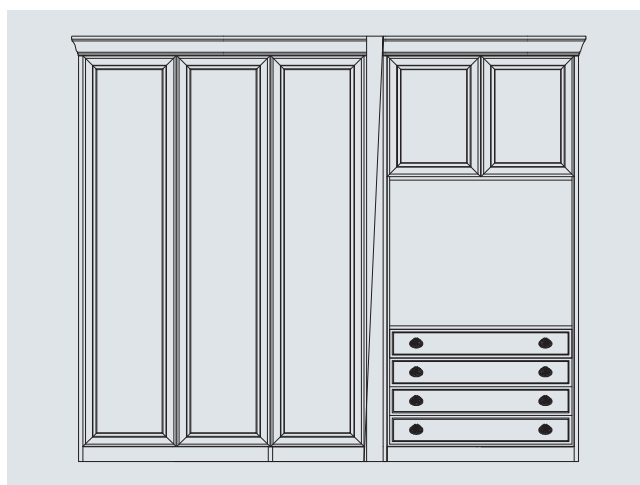

**104** - Composizione armadio ad angolo 5 ante + cassetti + vano TV  
**104** - 5-door angular composition + drawers + TV compartment  
**104** - Composicion angular 5 puertas + cajones + compartimento de TV

256+195 x 65 x 253

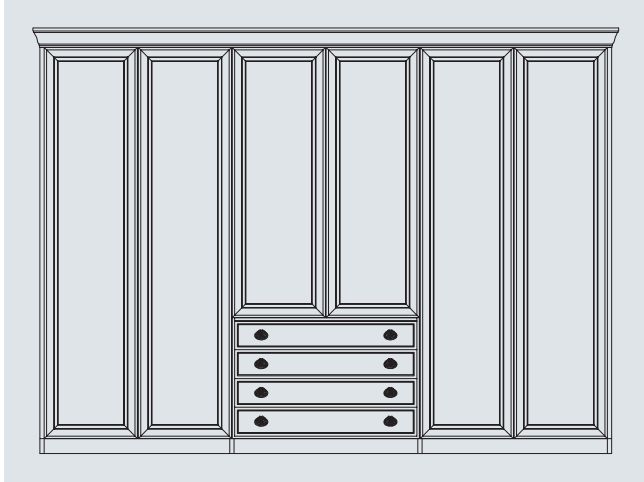

**105** - Composizione armadio 6 ante + cassetti  
**105** - 6-door wardrobe composition + drawers  
**105** - Composicion armario 6 puertas + cajones

376 x 65 x 253

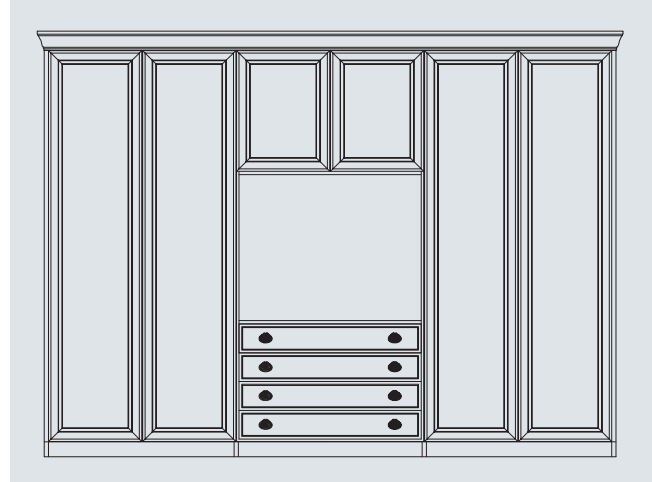

**106** - Composizione armadio 6 ante + cassetti + vano TV  
**106** - 6-door wardrobe composition + drawers + TV Compartment  
**106** - Composicion armario 6 puertas + cajones + compartimiento de TV

376 x 65 x 253

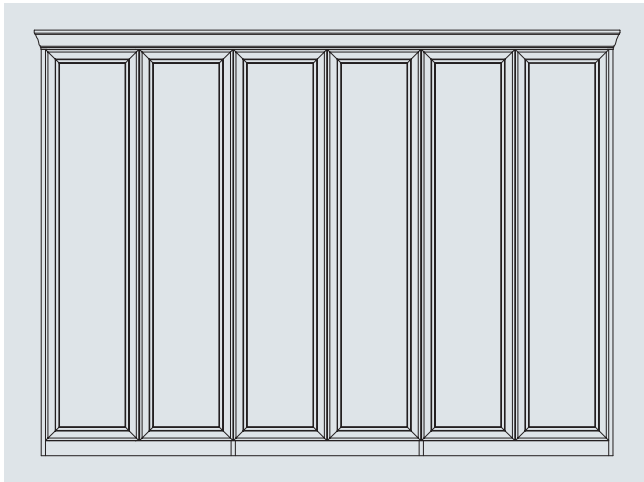

**107** - Composizione armadio 6 ante  
**107** - 6-door wardrobe composition  
**107** - Composicion armario 6 puertas

376 x 65 x 253





## Le Fablier SpA

via del Lavoro, 2  
37067 Valeggio sul Mincio - Verona  
tel +39 045 6372000  
fax +39 045 6372001  
www.lefablier.it  
info@lefablier.it  
skype: lefablier



## Le Gemme

design  
**Le Fablier S.p.A.**  
ufficio ricerca e sviluppo/  
R&D office

graphic design  
**Francesca Meneguzzi**

fotografia/  
photography  
**Mauro Negro**

assistenti alla fotografia/  
photography assistants  
**Marzio De Santis**

coordinamento/  
coordination  
**Paola Storace**

stampa/  
print  
**OGM**

Grazie a/  
Thanks to

FEDON - [www.fedongroup.com](http://www.fedongroup.com)

La Redoute - [www.laredoute.it](http://www.laredoute.it)

Club Des Sports - [www.clubdessports.eu](http://www.clubdessports.eu)

PT01 Pantaloni Torino - [www.pt01.it](http://www.pt01.it)

Historic Research - [www.historic-research.it](http://www.historic-research.it)

Rimowa - [www.rimowa.de](http://www.rimowa.de)

Nava Design - [www.navadesign.com](http://www.navadesign.com)

Thinkashmir - [www.thinkashmir.com](http://www.thinkashmir.com)

Happidea - [www.happidea.it](http://www.happidea.it)

Lampade - Luci e Forme Le Fablier (VR)

1ª edizione – Febbraio 2011

Il catalogo è di proprietà esclusiva di Le Fablier S.p.A.  
– Tutti i diritti sono riservati. È vietata ogni forma di riproduzione anche parziale.

*This catalogue is of exclusive property of Le Fablier S.p.A.  
– All right are reserved. Any form of total or partial reproduction of the catalogue is strictly forbidden.*

*El catálogo es de propiedad exclusiva de Le Fablier Spa- todos los derechos están reservados. Cualquier forma de reproducción, incluso parcial, está prohibida.*

Il marchio e il logo "Le Fablier – valori per sempre" sono depositati e registrati.

*The "Le Fablier – valori per sempre" brand and logo are filed and registered.*

*La marca y el logo « Le Fablier – valori per sempre » están registrados.*

La stampa tipografica non sempre riproduce fedelmente le tinte degli originali.

*The printing process do not always permit a faithful reproduction of tones of originals.*

*La impresión tipográfica no reproduce siempre con fidelidad los colores originales.*

Le Fablier si riserva la facoltà di apportare in qualsiasi momento modifiche tecniche e dimensionali ai modelli, anche senza preavviso.

*Le Fablier reserves the right to change, in any time and without prior warning, the technical specifications and dimensions of the artides.*

*Le Fablier se reserva el derecho de hacer, en cualquier momento, modificaciones técnicas y dimensionales, a los modelos, sin previo aviso.*



